

PELCO® EPOXY PUMP SET, PK/2 Product Number 813-503



The enclosed plunger pumps can be used to meter and dispense PELCO® epoxy resin and hardener. They fit directly into the gallon, ½ gallon and quart bottles. The pumps dispense about one fluid ounce per full stroke. If you do not choose to install a restrictor on the hardener pump, then use two strokes of resin to one stroke of hardener to achieve a two to one ratio; or use three strokes of resin to one stroke of hardener to achieve a three to one ratio.

Enclosed with each set of pumps is a small plastic tube (restrictor) which is slotted down one side. This can be placed on the hardener pump to limit the stroke by 50%. The restrictor must be placed between the pump cap and double flared seal at base. With the restrictor installed on the hardener pump, one stroke of the epoxy resin pump (one fluid ounce, 29 mL) and one stroke of the hardener pump (1/2 fluid ounce, 14.75 mL) yields the proper mix ratio of two to one by volume.

NOTE: When pumping multiple strokes for large batches, alternate pumping one stroke of resin then one stroke of hardener- this allows time for the pump to return all the way to the top and also keeps the number of resin strokes equal to the number of hardener strokes. **DO NOT** pull up on the plunger when it is returning to its original position, so as to not trap air within the pump.

USING THE PUMP:

Remove the inlet tube and slide it into the hole at base of pump. Install into jug. You will need to cut the inlet tube when putting it into a 1/2 gallon or quart bottle. When cutting, it works best if you cut the tube at a slant. Prime by pumping up and down a few times to make certain that all air is expelled from the pump. If this priming is difficult, then warm the material in the jug. Double check to make sure that the pumps you are using are metered in the proper volumetric ratio. Units that have stood unused for several days or more should be pumped a few times to remove any air that may have seeped into the system. Check ratio if pump burps. Ignore burping if ratio is correct.

INSTALLING THE RESTRICTOR:

Disassemble the pump by unscrewing the pump body at the cap. Slide cap towards top of pump. Place restrictor between pump cap and double flared seal at base. Make certain that the restrictor is seated in the slot at the base of the pump (see diagram to the right) and reassemble.

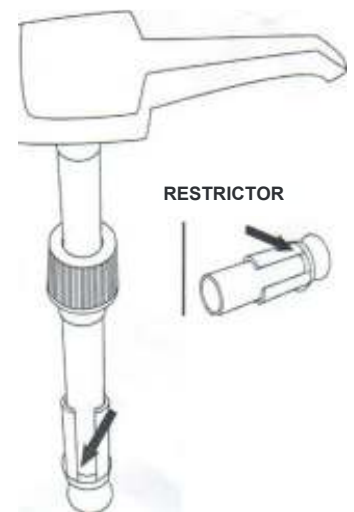

813-503 TN V1 03092011

Page 1 of 1